

## FT-200 N LED NEW!



Category XB1 directional lamps generating emergency light have been fitted with 6 extraordinarily efficient OSRAM LEDs. Owing to the double lens system implemented in the lamp, the light emitted by the diodes is focused and cast in the right direction. The light signal will therefore be noticed even in dire weather conditions, both during the day and at night. Luminous efficacy of the lamp is at a level never seen before. The lamp emits a few fully certified light flashes that are easily customisable in a user-friendly manner. Additionally, all FT-200N lamps are equipped with two synchronisation groups that render the light signals emitted by the vehicle structured and easy on passers-by.

The lamp housing, made of an impact-resistant material, has been combined with a lampshade made of polycarbonate (PC) to create a product that is extremely durable and resistant to mechanical damage, shocks as well as moisture, all of which is attested by relevant certificates.

High reliability, modern shape, and compact design of the lamp make this product widely used in a variety of present-day emergency vehicles, e.g. ambulances, financial law enforcement vans, or tankers of sanitisation companies.

#### Technical specifications:

- 6 OSRAM LEDs
- Operating voltage range 12 – 36V DC

- **Power consumption: 12V/24V/ Peak power consumption: 0.6A/0.3A**
- Rated power: Peak = 8 watts
- Homologation of warning lamps **ECE no. 65 (XA1)**
- Flash frequency: **f = 2Hz** (single, double, triple flash)
- Certificate of electromagnetic compatibility – **(EMC)**
- Fully waterproof lamp – **IP68**
- Shock-resistant lamp – **IK**
- Optimal lamp operating temperature: **-40°C to +55°C**
- The lamp has a reverse polarity protection system
- Ground** – white wire; **PLUS** – black wire;
- Synchronisation/programme change** – yellow wire

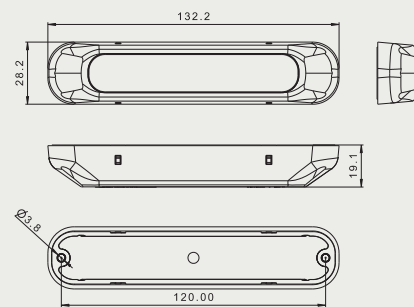
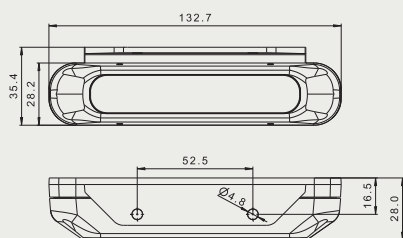
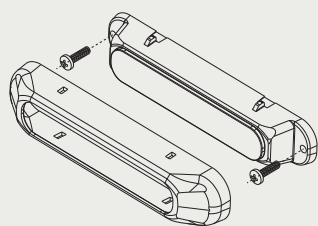

... all you need is light

**BIURO:**  
FRISTOM  
Spółka z ograniczoną odpowiedzialnością i Sp. K.  
ul. Grunwaldzka 207A  
POLAND, 85-451 Bydgoszcz

**EXPORT:**  
mobile +48 609 909 456  
bstaniaszek@fristom.com.pl  
mobile +48 607 843 275  
wsaran@fristom.com.pl